

Terram Trinter Soil Retention Mat for Erosion Control

TERRAM

Geosynthetics

dataX1 Data GB
01 March 2001 • 1 of 2

Property	Test Method	Units	Value
Mechanical Properties			
Wide width tensile strength	EN ISO 10319 ⁽¹⁾	kN/m	3.5
Elongation	EN ISO 10319 ⁽¹⁾	%	20
Polymer Properties			
Polymer type			PP and HDPE
UV resistance			UV stabilisers and 2% carbon black
Colour			Black
Physical Properties			
Unit weight		g/m ²	340
Thickness		mm	20 to 25
Roll width		m	2.0
Roll length		m	25
Approx. Roll diameter		m	0.7
Approx. Roll weight		kg	18

(1) Wide width tensile test using a modified EN ISO 10319 test in the principal direction.
Values quoted are family means derived over a period of time.

Terram Ltd
Mamhilad, Pontypool
Gwent NP4 0YR, United Kingdom
Tel: +44 (0) 1495 767 444
Fax: +44 (0) 1495 762 393
Email: info@terram.co.uk
Web: www.terram.com



EN ISO 9002

The information contained herein is offered free of charge and is, to the best of our knowledge, accurate. However, since the circumstances and conditions in which such information and the products discussed therein can be used may vary and are beyond our control, we make no warranty, express or implied, of merchantability, fitness or otherwise, or against patent infringement, and we accept no liability, with respect to or arising from use of such information or any such product.

Terram Trinter Soil Retention Mat Installation Guide

TERRAM

Geosynthetics

data

X1 Data GB
01 March 2001 • 2 of 2

Application

Steep slopes, river banks, ditches, spillways and other exposed areas are often prone to damage caused by erosion of soil by wind or water. Vegetation can help protect against these erosive forces but often the soil is washed away before the vegetation is able to establish a strong root system. Terram Trinter Soil Retention Mat reduces the destructive forces of water and wind and provides a long term root reinforcement system.

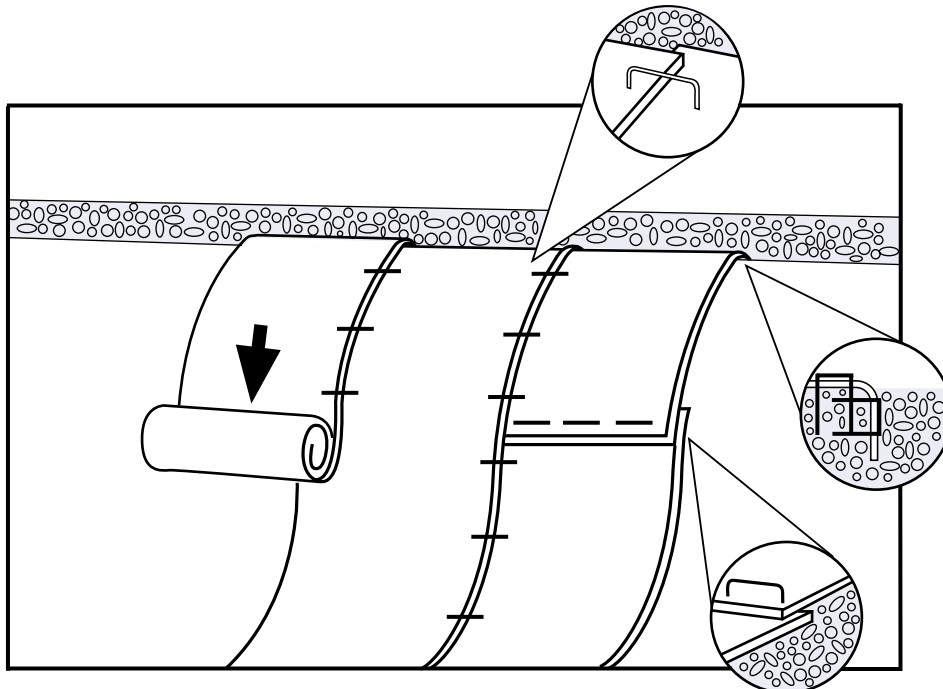

Installation

Excavate the slope, fill any voids and make smooth with no ruts or undulations. Secure the Trinter Mat at the top of the slope into an anchor trench and/or fix using steel pins.

Unroll Trinter down the slope ensuring that the 'soil pockets' run horizontally. At each roll change place the leading edge under the preceding roll with a 100mm overlap. Secure the lap with steel pins. Continue installation along the slope length and overlap adjacent rolls by 100mm. Secure the overlap using steel pins at 1m centres.

Fill the Trinter Mat with topsoil ensuring that there are no gaps between the soil filled Trinter and the slope surface. Hydroseed onto the soil filled mat to encourage vegetation.

The information contained herein is offered free of charge and is, to the best of our knowledge, accurate. However, since the circumstances and conditions in which such information and the products discussed therein can be used may vary and are beyond our control, we make no warranty, express or implied, of merchantability, fitness or otherwise, or against patent infringement, and we accept no liability, with respect to or arising from use of such information or any such product.